

CAST IRON Y STRAINER FLANGED PN 10/16 DIN 3202-1 F1

PRODUCT EVOLUTION



Be careful, our strainers Ref.220 are changing

We currently have 2 different types available in DN20 with different dimensions, screen and gaskets:

Old type:



New type:



At the end, only the new type will be available (from page 2 to 9)

CAST IRON Y STRAINER FLANGED PN 10/16 DIN 3202-1 F1

Cast iron Y strainer flanged PN10/16 for filtration of water distribution, heating, water treatment and irrigation networks.
Strainer with removable filter and bolted bonnet
Threaded BSP draining cap allowing to install a draining valve.

Certificate

3.1



- Size :** DN15 to DN600
Connection : Flanges RF PN10/16
Min Temperature : -10°C
Max Temperature : +120°C
Max Pressure : 16 Bars up to DN200 (10 bars over)
Caractéristiques : Removable stainless steel filter
Bolted bonnet with draining cap
Alkyd painting
- Materials :** Ductile iron EN GJS-500-7 (from DN50 to 300)

CAST IRON Y STRAINER FLANGED PN 10/16 DIN 3202-1 F1

SPECIFICATIONS :

- Removable stainless steel filter
- R.F. flanges PN10/16
- Horizontal or vertical position with descendant fluid (respect the flow direction indicated by the arrow)
- Mesh : see tab page 4
- Bolted bonnet with draining cap threaded BSP
- Alkyd painting color grey RAL 7011, 100 µm thickness

USE :

- For water distribution, heating, watering, irrigation
- Min Temperature Ts : - 10°C
- Max Temperature Ts :+ 120°C
- Max Pressure Ps : 16 bars up to DN200 , 10 bars over

HEAD LOSS GRAPH DN40-400 :

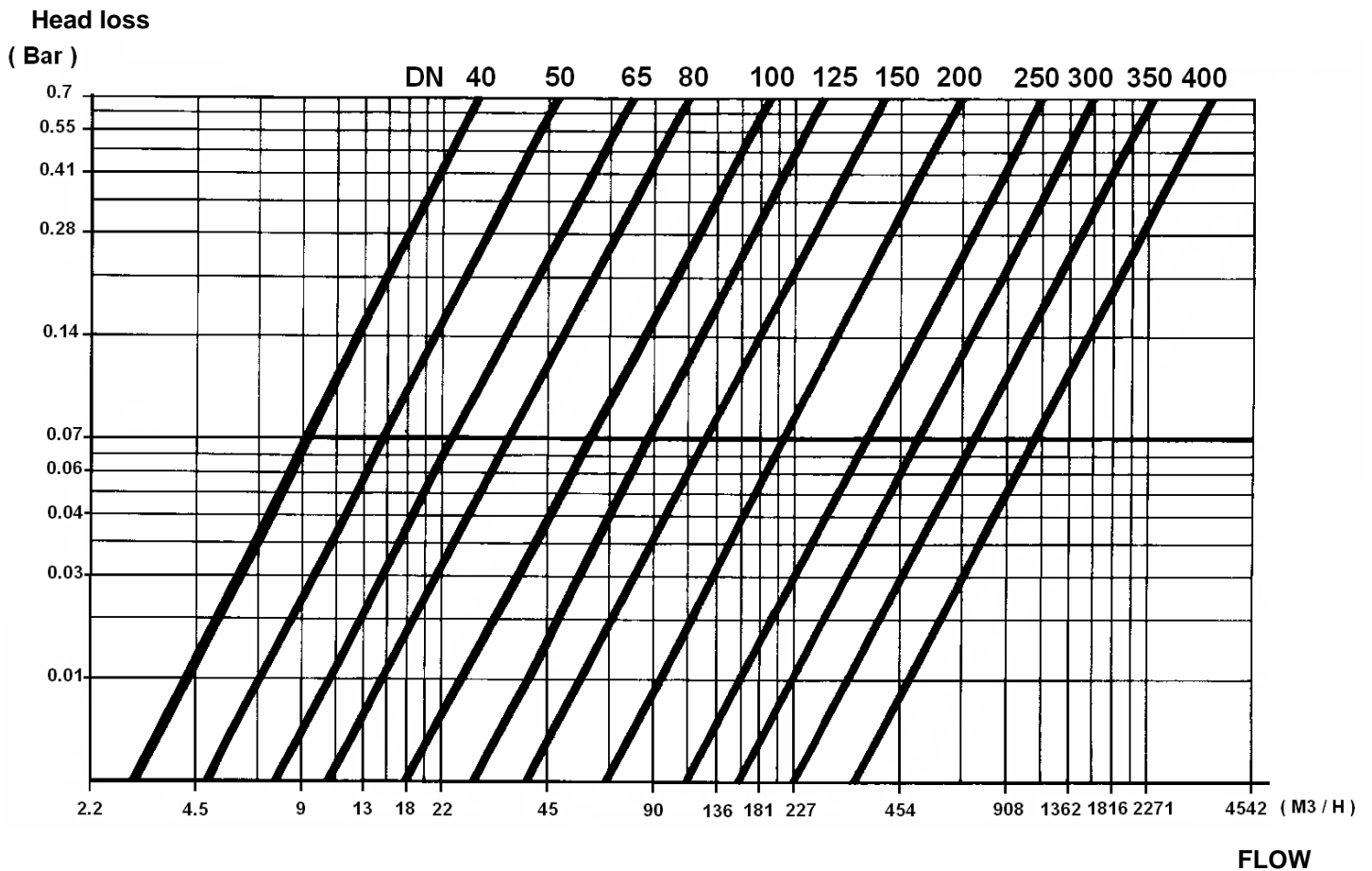

CAST IRON Y STRAINER FLANGED PN 10/16 DIN 3202-1 F1

HEAD LOSS GRAPH DN450-600 :

Head loss (KPa)

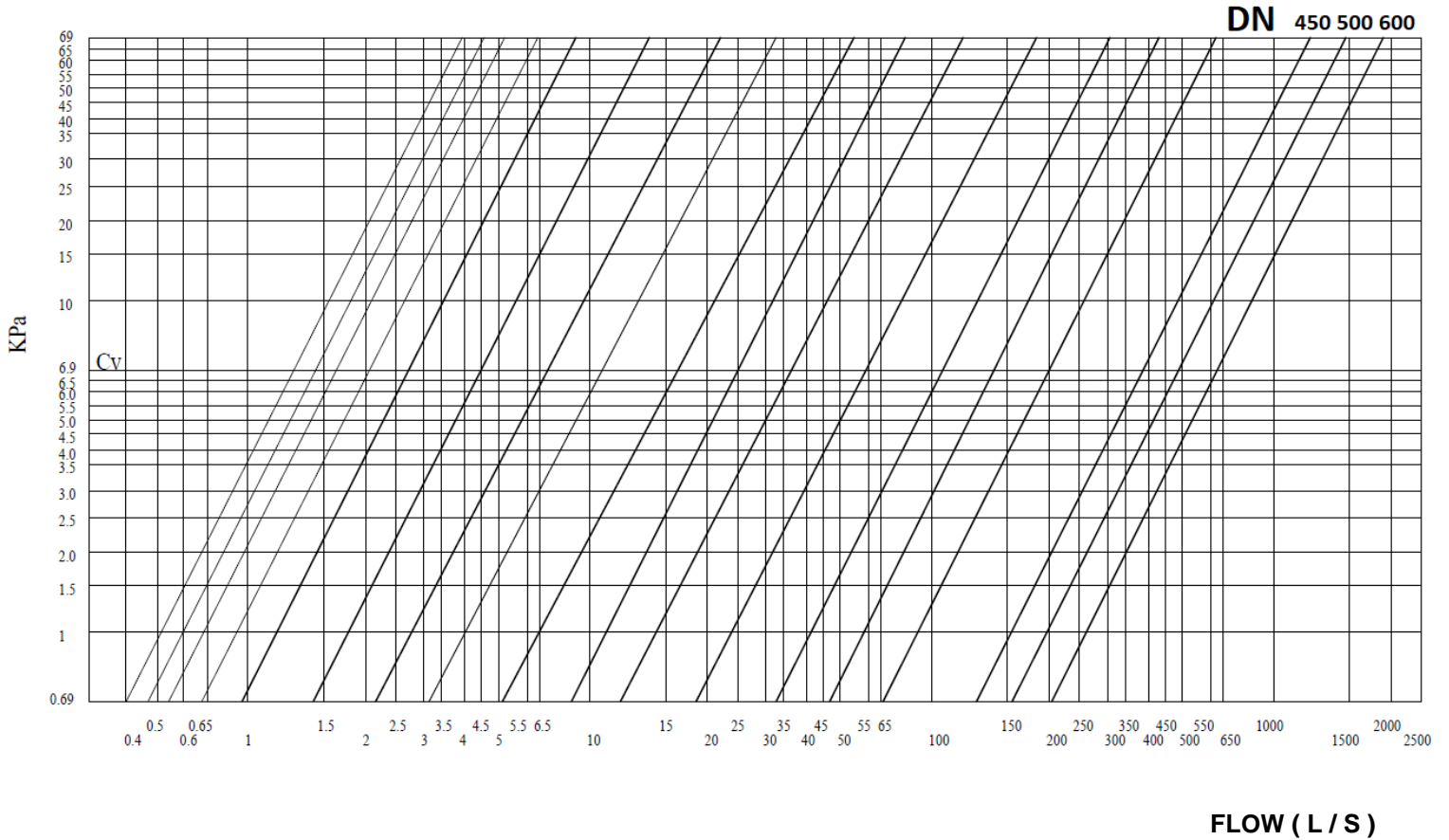

10 KPa = 0.1 bar

1000 L/S = 3600 M3/H

CAST IRON Y STRAINER FLANGED PN 10/16 DIN 3202-1 F1

RANGE :

- R.F. flanges PN10/16 from DN 15 to 300, PN10 over

MATERIALS :

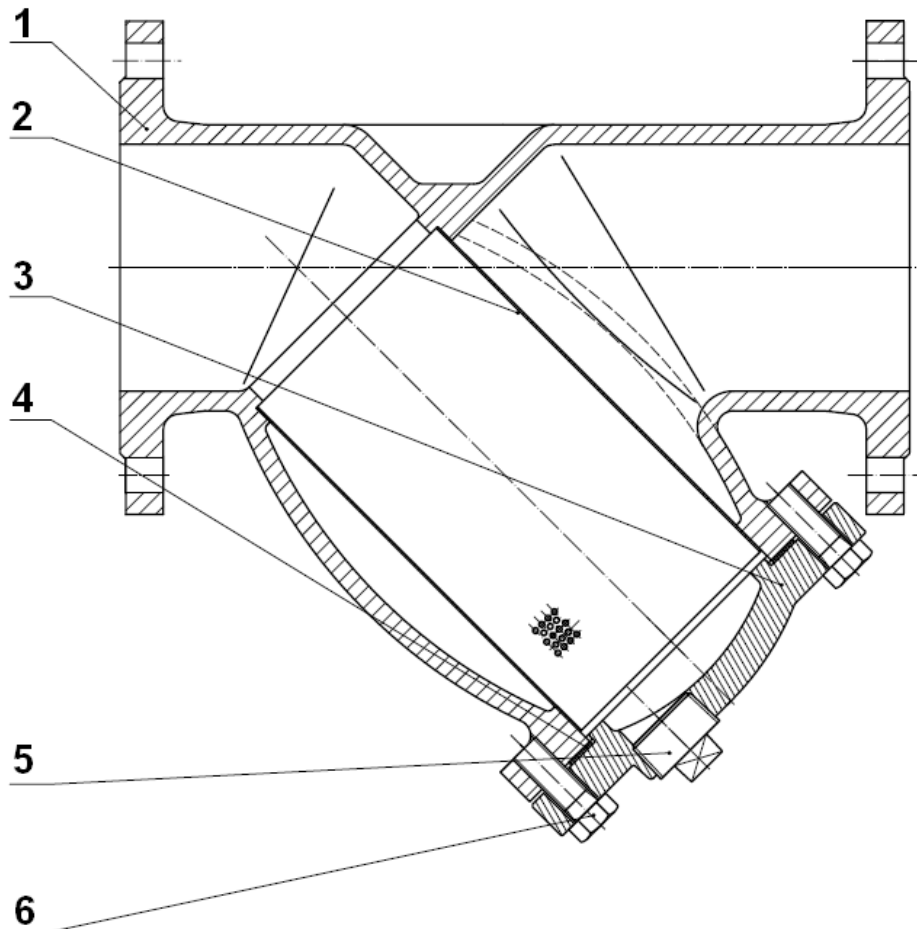

Item	Designation	Materials from DN15 to 40 and from DN350 to 600	Materials from DN50 to DN300
1	Body	Cast iron EN GJL-250	Ductile iron EN GJS-500-7
2	Screen	AISI 304	AISI 304
3	Bonnet	Cast iron EN GJL-250	Ductile iron EN GJS-500-7
4	Bonnet gasket	Graphite	Graphite
5	Draining cap	Brass	Brass
6	Bonnet screw	Steel Rst 37-2	Steel Q235

CAST IRON Y STRAINER FLANGED PN 10/16 DIN 3202-1 F1

SIZE (in mm) :

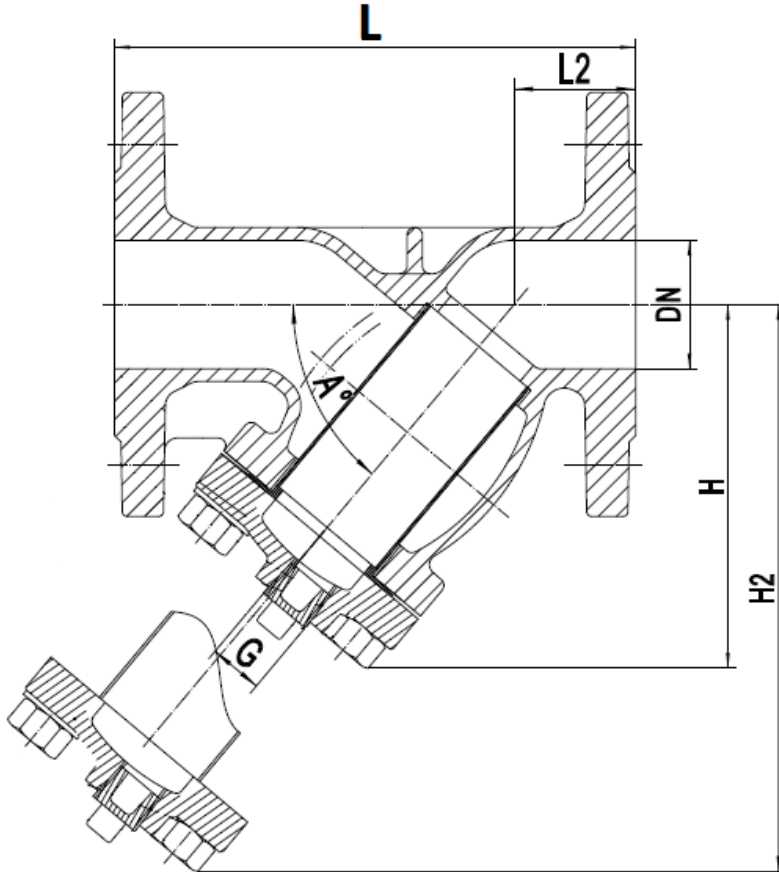

Filter size :

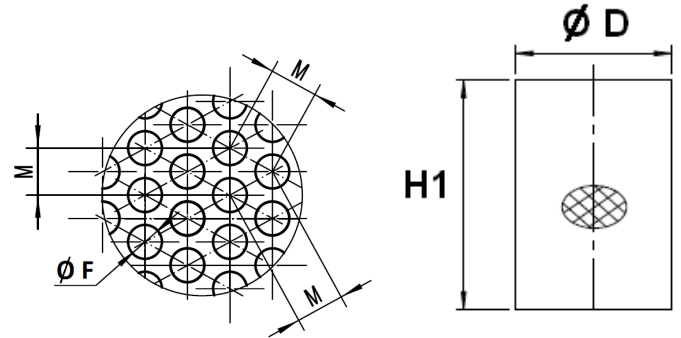

DN	15	20	25	32	40	50	65	80	100	125	150	200
L	130	150	160	180	200	230	290	310	350	400	480	600
L2	39	38	38	43	53.5	70	94	95	97.5	109.5	136.5	189.5
H	76	90	108	117	132	123	148	163	208	248	276	355
H2	112	138	161	186	213	192	234	270	339	400	450	577
A (°)	50	50	50	50	50	55	55	55	55	55	55	55
G (drain)	1/4"	1/4"	1/4"	1/2"	1/2"	1/2"	1/2"	1/2"	1/2"	1/2"	1/2"	1/2"
Ø D	16	22	28	35	41	54	69	85	105	132.5	159.5	212.5
H1	46	60	72	86	101	79	100	119	152	179	202	265
Mesh (Ø F)	1.2					1.5					2	2.5
M	2.4					2.5					3	4
Weig. (Kg)	2.2	3	3.7	5.8	7.1	8.5	11.4	14.2	20.5	31.2	40.2	68
Ref.	220015	220020	220025	220032	220040	220050	220065	220080	220100	220125	220150	220200-220201

CAST IRON Y STRAINER FLANGED PN 10/16 DIN 3202-1 F1

SIZE (in mm) :

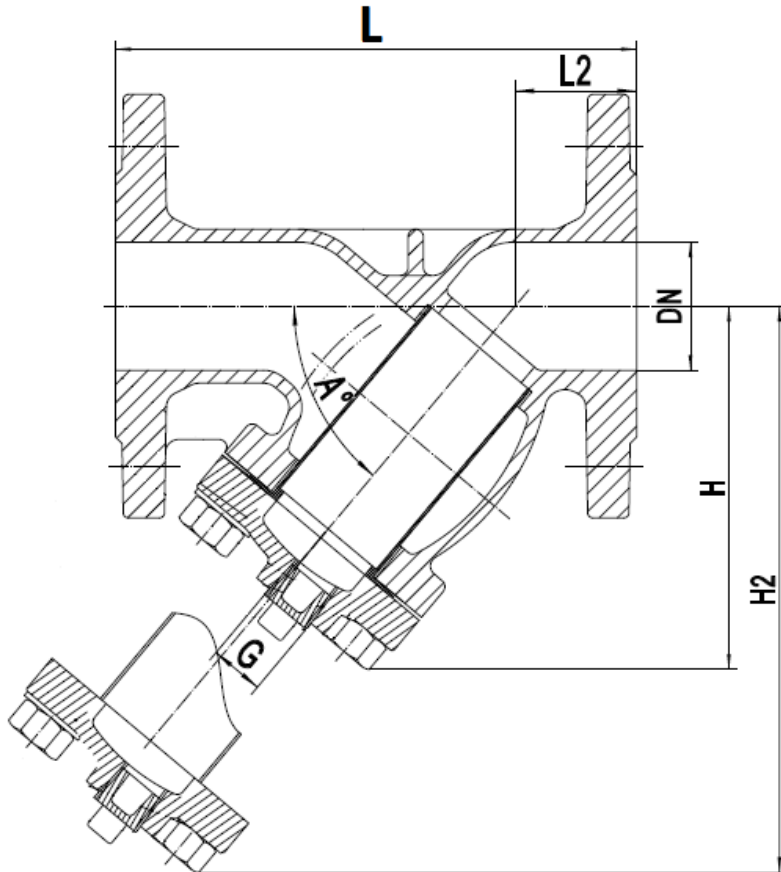

Filter size :

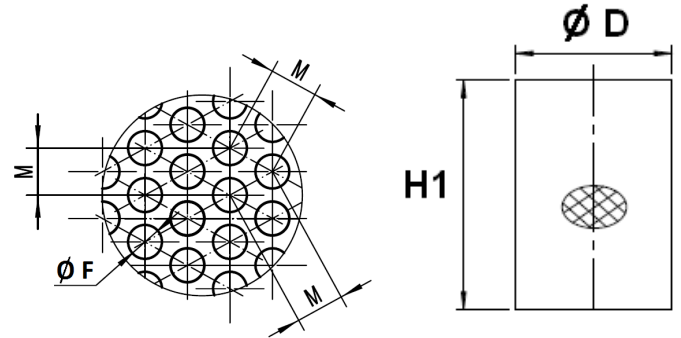

DN	250	300	350	400	450	500	600
L	730	850	980	1100	1200	1250	1450
L2	217.5	250.5	238.6	236.9	300	325	425
H	458	530	648	759	784	856	988
H2	744	878	1024	1211	1260	1385	1585
A (°)	55	55	45	45	50	50	50
G (drain)	1/2"	1/2"	1/2"	1/2"	3/4"		
Ø D	258	307	353	403	460	510	610
H1	344	420	540	650	617	683	779
Mesh (Ø F)	3	3	1.5	1.5	5	5	5
M	5		2.5		7	7	7
Weig. (Kg)	106	146	312	420	510	640	1072
Ref.	220250- 220251	220300- 220301	220350	220400	220450	220500	220600

CAST IRON Y STRAINER FLANGED PN 10/16 DIN 3202-1 F1

FLANGES SIZE PN10/16 (in mm) :

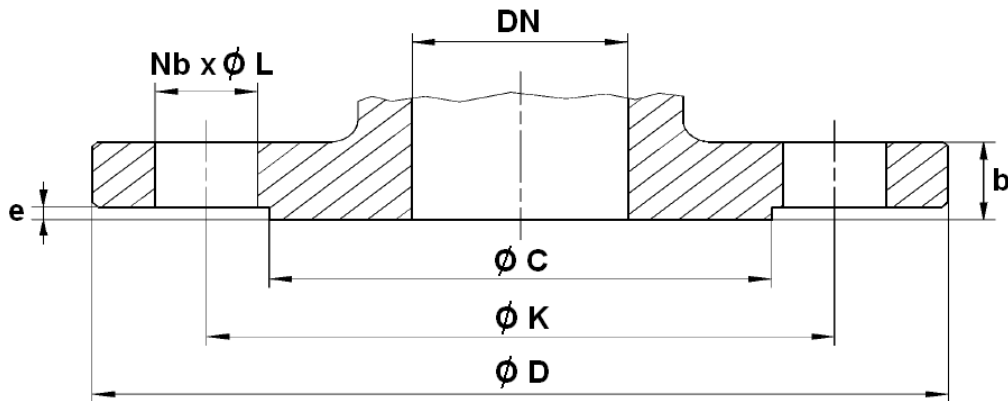

DN	15	20	25	32	40	50	65	80	100	125	150
Ø C	46	56	65	76	84	99	118	132	156	184	211
Ø D	95	105	115	140	150	165	185	200	220	250	285
Ø K	65	75	85	100	110	125	145	160	180	210	240
Nb x Ø L	4 x 14	4 x 14	4 x 14	4 x 19	4 x 19	4 x 19	4 x 19	8 x 19	8 x 19	8 x 19	8 x 23
b	14	16	16	18	18	19	19	19	19	19	19
e	2	2	3	3	3	3	3	3	3	3	3
Ref.	220015	220020	220025	220032	220040	220050	220065	220080	220100	220125	220150

CAST IRON Y STRAINER FLANGED PN 10/16 DIN 3202-1 F1

FLANGES SIZE PN10 (in mm) :

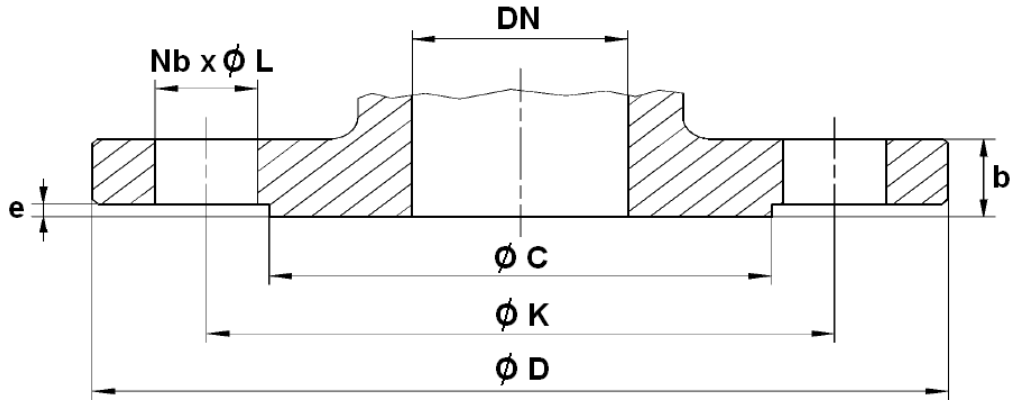

DN	200	250	300	350	400	450	500	600
Ø C	266	319	370	429	480	530	582	682
Ø D	340	405	460	520	580	640	715	840
Ø K	295	350	400	460	515	565	620	725
Nb x Ø L	8 x 23	12 x 23	12 x 23	16 x 23	16 x 28	20 x 28	20 x 28	20 x 31
b	20	22	24.5	36	38	40	42	48
e	3	3	4	4	4	4	4	5
Ref.	220201	220250	220300	220350	220400	220450	220500	220600

FLANGES SIZE PN16 (in mm) :

DN	200	250	300
Ø C	266	319	370
Ø D	340	405	460
Ø K	295	355	410
Nb x Ø L	12 x 23	12 x 28	12 x 28
b	20	22	24.5
e	3	3	4
Ref.	220200	220251	220301

CAST IRON Y STRAINER FLANGED PN 10/16 DIN 3202-1 F1

STANDARDS :

- Manufacturer certified ISO 9001 : 2015
- DIRECTIVE 2014/68/EU : Product excluded from directive (Article 4, § 3)
- Certificate 3.1 on request
- Length according to EN 558 series 1 (DIN 3202-1 F1, NF 29354)
- R.F. flanges according to EN 1092-2 PN10/16

INSTALLATION POSITIONS :

Vertical position (descendand fluid)



Horizontal position



ADVICE : Our opinion and our advice are not guaranteed and SFERACO shall not be liable for the consequences of damages. The customer must check the right choice of the products with the real service conditions.

CAST IRON Y STRAINER FLANGED PN 10/16 DIN 3202-1 F1**INSTALLATION INSTRUCTIONS****GENERAL GUIDELINES :**

- Ensure that the strainers to be used are appropriate for the conditions of the installation (type of fluid, pressure and temperature).
- Be sure to have enough valves to be able to isolate the sections of piping as well as the appropriate equipment for maintenance and repair.
- Ensure that the strainers to be installed are of correct strength to be able to support the capacity of their usage.
- **Installation of all circuits should ensure that their function can be automatically tested on a regular basis (at least two times a year).**

INSTALLATION INSTRUCTIONS :

- **Before installing the strainers, clean and remove any objects from the pipes** (in particular bits of sealing and metal) which could obstruct and block the strainers.
- **Ensure that both connecting pipes either side of the strainer (upstream and downstream) are aligned (if they're not, the strainer may not work correctly).**
- **Make sure that the two sections of the pipe (upstream and downstream) match, the strainer unit will not absorb any gaps. Any distortions in the pipes may affect the tightness of the connection, the working of the strainer and can even cause a rupture.** To be sure, place the kit in position to ensure the assembling will work.
- Make sure flanges are cleaned.
- **If sections of piping do not have their final support in place, they should be temporarily fixed. This is to avoid unnecessary strain on the strainer.**
- Tighten the bolts in cross.
- The pressurisation must be increased gradually.
- So that the maintenance operations could be easily done, place a stop valve before and after the strainer. Thereby, the strainer could be isolated. During this operation, ensure to have a new bonnet gasket to avoid a leakage during the restarting.
- **Fluids in the strainer must not contain solid objects (it could damaged the seat).**

CAST IRON Y STRAINER FLANGED PN 10/16 DIN 3202-1 F1



Certificate 3.1



Size : DN 20
Ends : Flanges R.F. PN10/16
Min Temperature : - 10°C
Max Temperature : + 120°C
Max Pressure : 16 Bars up to DN 200 (10 bars over)
Specifications : Removable stainless steel filter
Bolted bonnet with draining cap

Materials : Cast iron body EN GJL-250

CAST IRON Y STRAINER FLANGED PN 10/16 DIN 3202-1 F1

SPECIFICATIONS :

- Removable stainless steel filter
- R.F. flanges PN10/16
- Horizontal or vertical position with descendant fluid (respect the flow direction indicated by the arrow)
- Mesh 1.1mm from DN 15 to 125, 1.5 mm from DN 150 to 300, 3 mm from DN 350 to 400 and 5 mm from DN450 to 600
- Bolted bonnet with draining cap threaded BSP
- Epoxy painting RAL 7011 color, 150µm thickness

USE :

- For water, water treatment, irrigation
- Min Temperature Ts : - 10°C
- Max Temperature Ts :+ 120°C
- Max Pressure Ps : 16 bars at 120°C up to DN200 , 10 bars over

HEAD LOSS GRAPH DN15-300 :

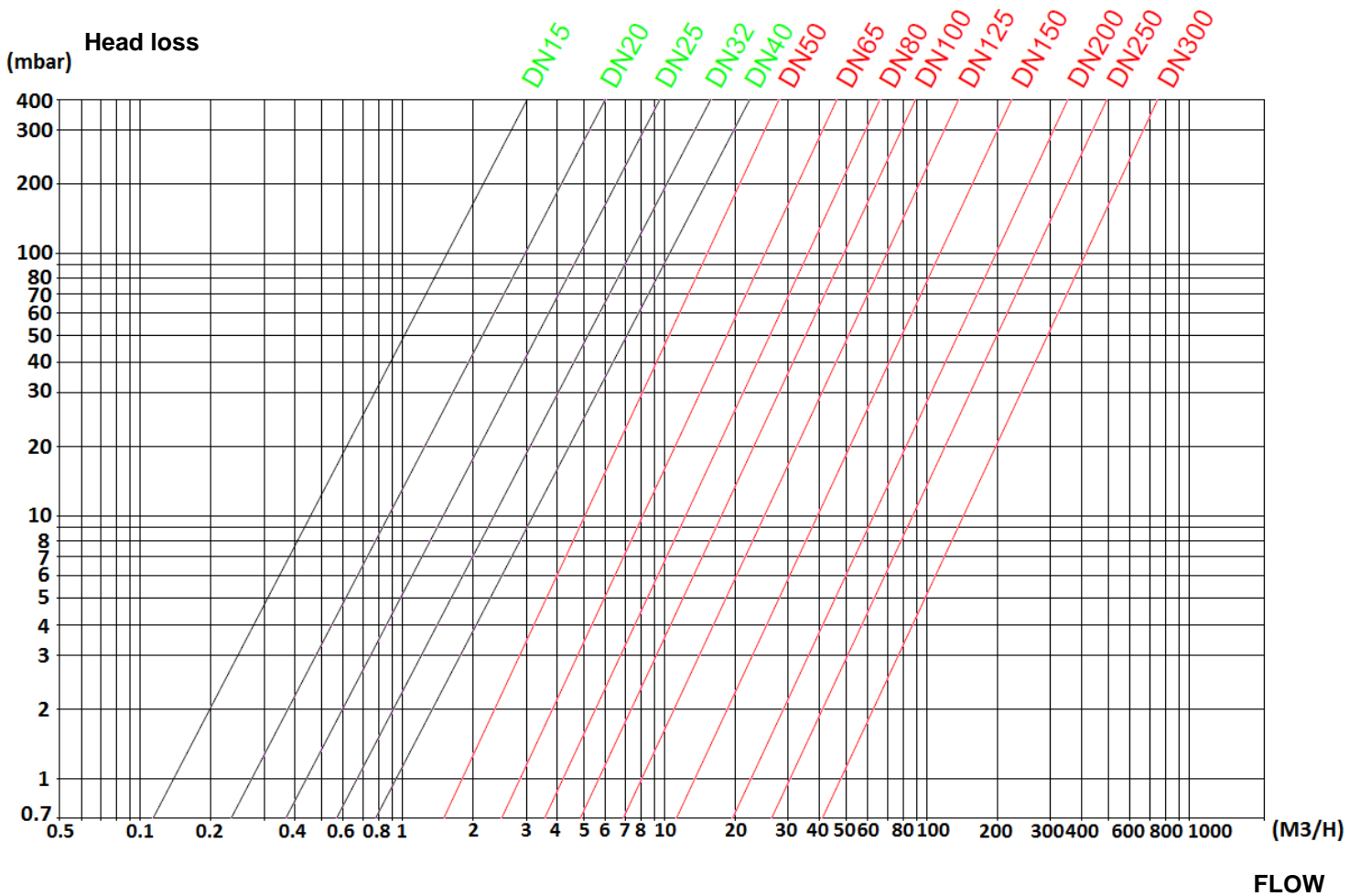

CAST IRON Y STRAINER FLANGED PN 10/16 DIN 3202-1 F1

RANGE :

- Cast iron Y strainer R.F. flanges PN10/16 from DN 15 to 600 Ref.220

MATERIALS DN15-300 :

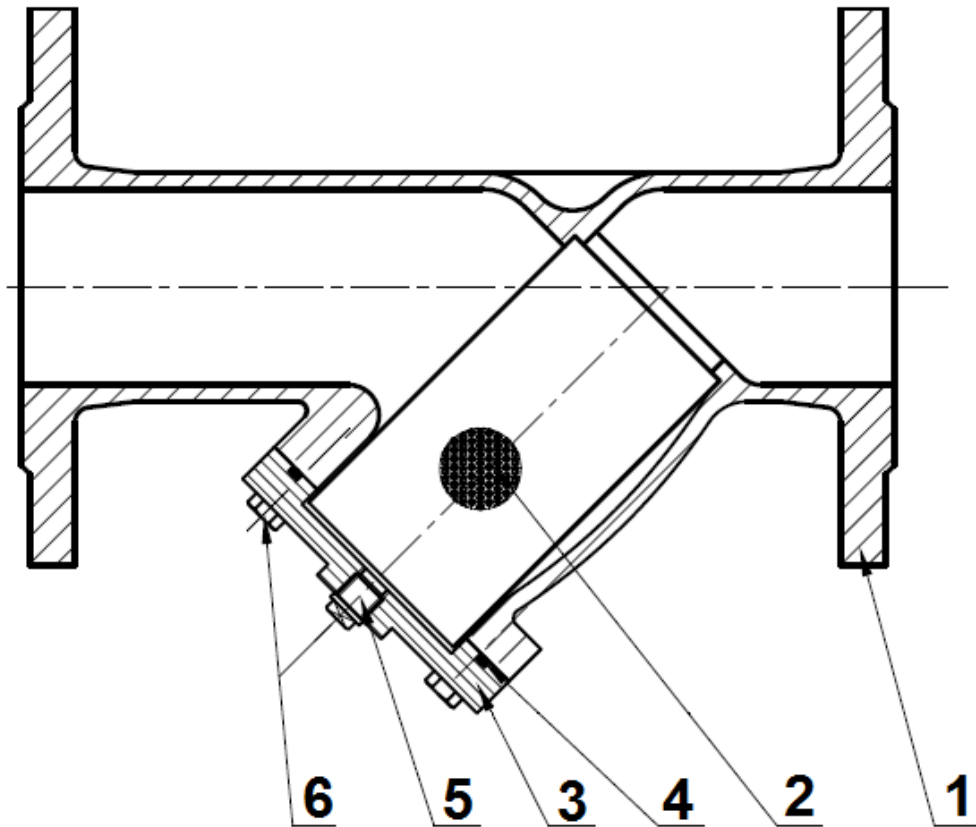

Item	Designation	Materials
1	Body	Cast iron EN GJL-250
2	Filter	AISI 304
3	Bonnet	Cast iron EN GJL-250
4	Bonnet gasket	Graphite + AISI 201
5	Draining cap	Brass
6	Bonnet screw	AISI 201

CAST IRON Y STRAINER FLANGED PN 10/16 DIN 3202-1 F1

SIZE DN20 (in mm) :

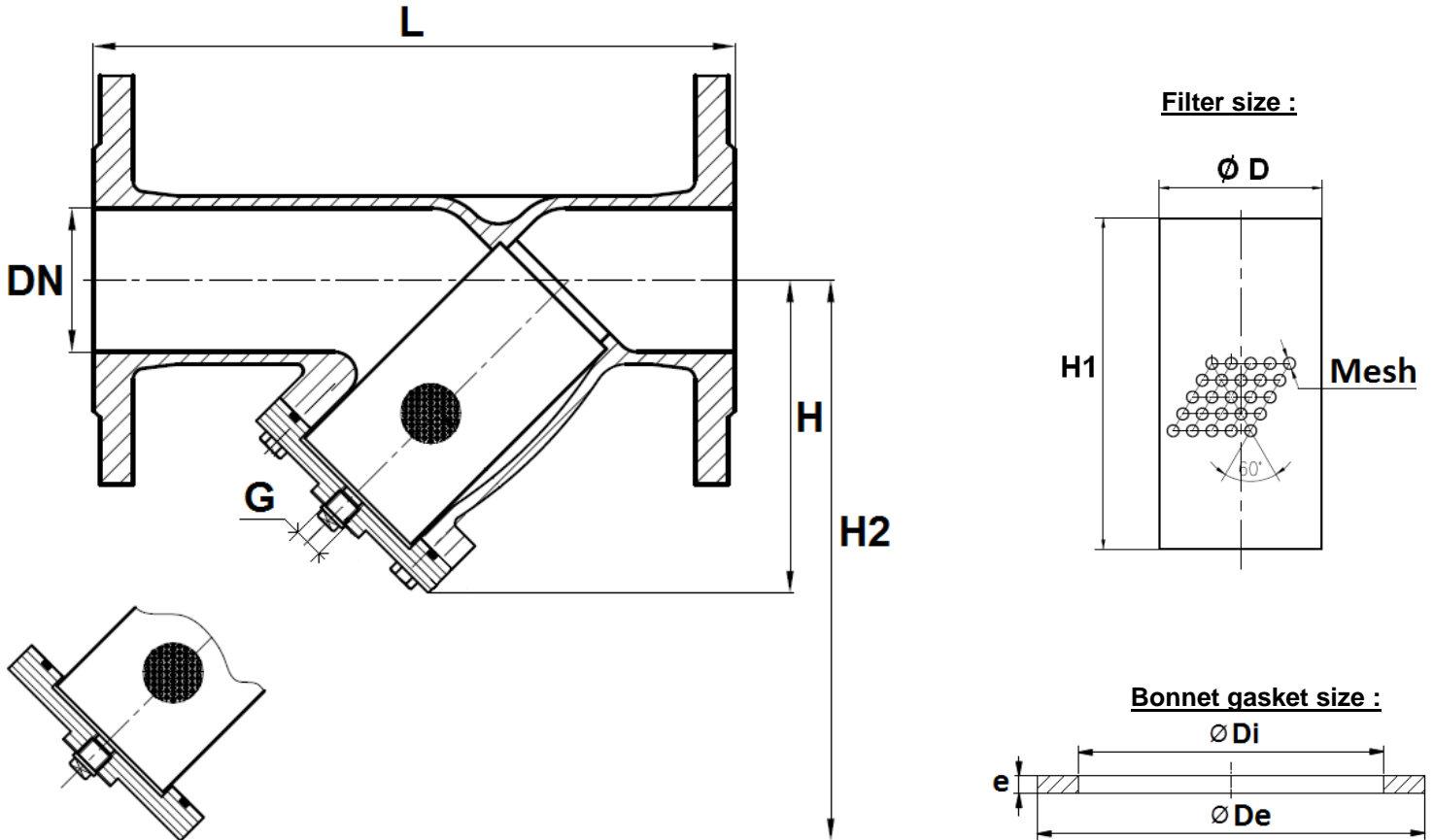

DN	20
L	150
H	91
H2	146
G (drain)	1/4"
Ø D	23
H1	71
Mesh	1.1
Ø Di	30
Ø De	42
E	3.6
Weight (in Kg)	3

CAST IRON Y STRAINER FLANGED PN 10/16 DIN 3202-1 F1

FLANGES SIZE PN10 (in mm) :

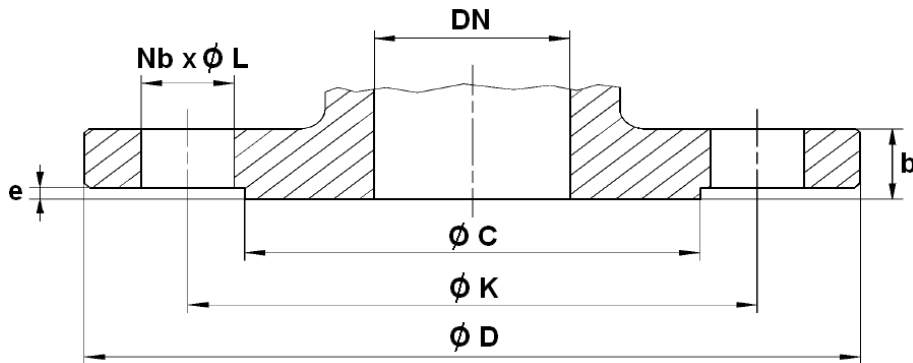

DN	20
Ø C	58
Ø D	105
Ø K	75
Nb x Ø L	4 x 14
b	16
e	2
Ref.	220020

STANDARDS :

- Fabrication according to ISO 9001 : 2015
- DIRECTIVE 2014/68/EU : Products excluded (article 4, § 3)
- Certificate 3.1 on request
- Pressure tests according to EN 12266-1
- Length according to EN 558 series 1 (DIN 3202-1 F1 – NF 29354)
- R.F. flanges according to EN 1092-2 PN10/16

CAST IRON Y STRAINER FLANGED PN 10/16 DIN 3202-1 F1

INSTALLATION POSITIONS :

Vertical position (descendand fluid)



Horizontal position

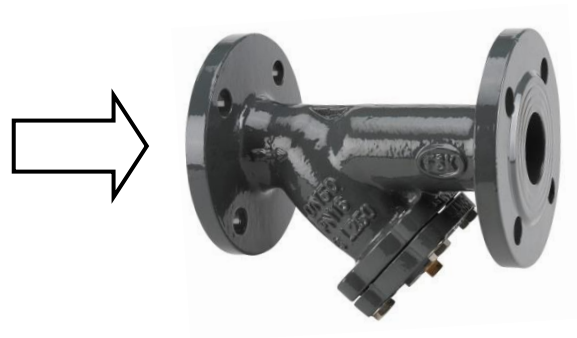

ADVICE : Our opinion and our advice are not guaranteed and SFERACO shall not be liable for the consequences of damages. The customer must check the right choice of the products with the real service conditions.

CAST IRON Y STRAINER FLANGED PN 10/16 DIN 3202-1 F1**INSTALLATION INSTRUCTIONS****GENERAL GUIDELINES :**

- Ensure that the strainers to be used are appropriate for the conditions of the installation (type of fluid, pressure and temperature).
- Be sure to have enough valves to be able to isolate the sections of piping as well as the appropriate equipment for maintenance and repair.
- Ensure that the strainers to be installed are of correct strength to be able to support the capacity of their usage.
- **Installation of all circuits should ensure that their function can be automatically tested on a regular basis (at least two times a year).**

INSTALLATION INSTRUCTIONS :

- **Before installing the strainers, clean and remove any objects from the pipes** (in particular bits of sealing and metal) which could obstruct and block the strainers.
- **Ensure that both connecting pipes either side of the strainer (upstream and downstream) are aligned (if they're not, the strainer may not work correctly).**
- **Make sure that the two sections of the pipe (upstream and downstream) match, the strainer unit will not absorb any gaps. Any distortions in the pipes may affect the tightness of the connection, the working of the strainer and can even cause a rupture.** To be sure, place the kit in position to ensure the assembling will work.
- Make sure flanges are cleaned.
- **If sections of piping do not have their final support in place, they should be temporarily fixed. This is to avoid unnecessary strain on the strainer.**
- Tighten the bolts in cross.
- The pressurisation must be increased gradually.
 - So that the maintenance operations could be easily done, place a stop valve before and after the strainer. Thereby, the strainer could be isolated. During this operation, ensure to have a new bonnet gasket to avoid a leakage during the restarting.
- **Fluids in the strainer must not contain solid objects (it could damaged the seat).**