

CAST IRON BALL VALVE PN 16 LENGTH DIN 3202

Cast iron ball valve with ISO 5211 mounting pad full bore for all common fluids of 2nd group.
2 FKM O Ring and 1 PTFE gasket on stem, PTFE body gasket and PTFE seat.
Compatible with explosive atmosphere, ATEX Zone 1&21 and Zone 2&22 thanks to the antistatic device.
Thanks to the ISO 5211 plate, an actuator can be installed on the valve.



Size : DN15 to DN200
Connection : Flanges PN10/16 RF
Min Temperature : -10°C
Max Temperature : +200°C
Max Pressure : 16 Bars
Specifications : PTFE seat
ISO 5211 mounting pad
Anti blow-out stem
Full bore
Stainless steel ball
ATEX

Materials : Cast iron EN GJL-250

CAST IRON BALL VALVE PN 16 LENGTH DIN 3202

SPECIFICATIONS :

- Full bore
- Anti blow-out stem
- With O ring FKM on stem and PTFE washer
- ISO 5211 mounting pad
- PN10/16 Flanges R.F. up to DN150 and PN16 for DN200 (Threaded holes flanges for DN 125 and 150)
- Solid stainless steel ball up to DN 25, hollow ball from DN 32 to DN 200
- Black painting colour RAL 9004 5-15 microns thickness

USE :

- For all common fluids of 2nd group
- Min and max Temperature Ts : - 10°C to + 200°C
- Max Pressure Ps : 16 bars
- **Do not use with steam**
- **Do not use with compressed air**

RANGE :

- Cast iron flanges R.F. with s.s. ball PN10/16 from DN15 to DN150 and PN16 for DN200 **Ref. 507** from DN 15 to DN 200

PRESSURE / TEMPERATURE GRAPH (STEAM EXCLUDED) :

P (bar)

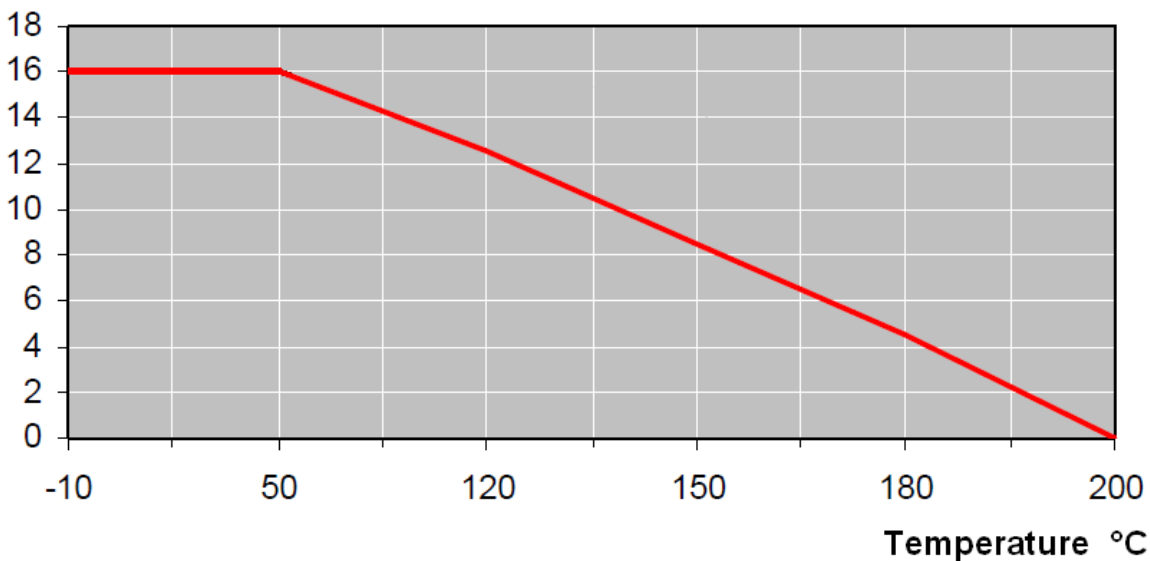

FLOW COEFFICIENT Kvs (in M3/H) :

DN	15	20	25	32	40	50	65	80	100	125	150	200
Kvs (M3 / H)	37.4	74.8	105	176	223	416	660	1200	1980	3600	5040	10890

TORQUE VALUES (in Nm without safety coefficient) :

DN	15	20	25	32	40	50	65	80	100	125	150	200
Torque (Nm)	6	6	11	12	26	41	41	71	119	190	220	450

CAST IRON BALL VALVE PN 16 LENGTH DIN 3202

MATERIALS :

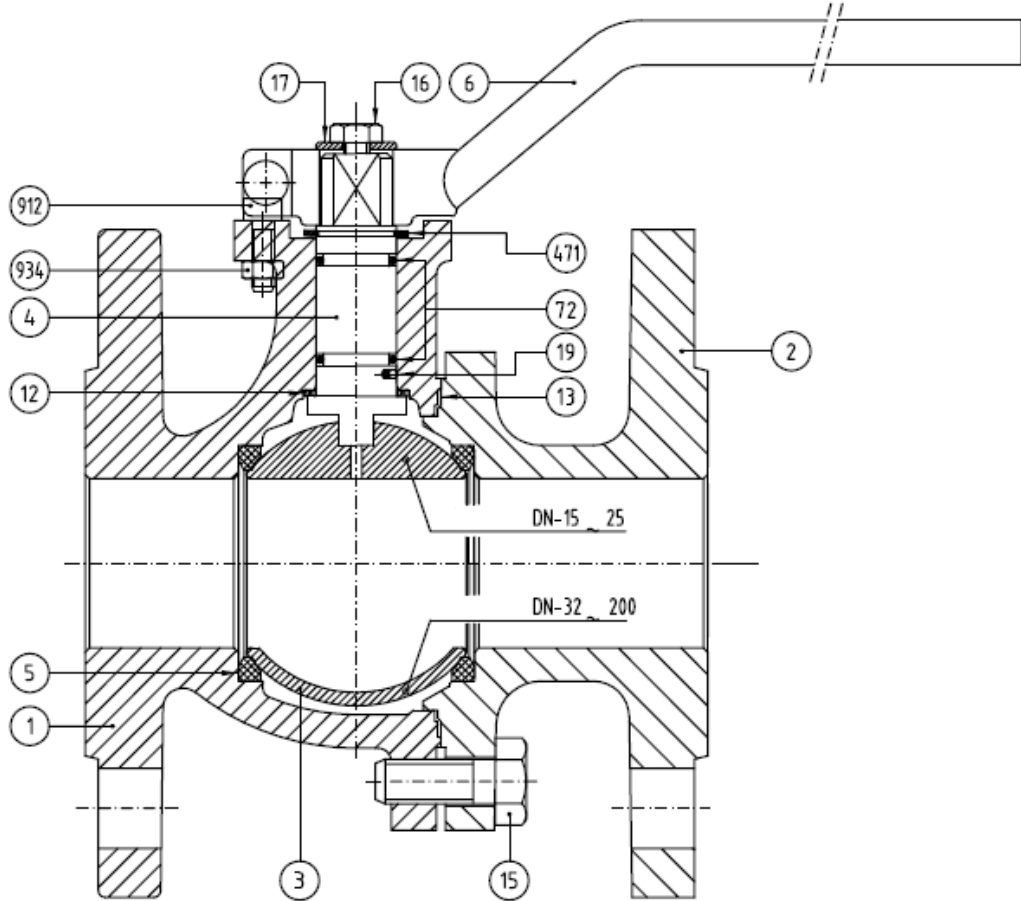

Item	Designation	Materials
1	Body	Cast iron EN GJL-250
2	Ends	Cast iron EN GJL-250
3	Ball DN15-25	AISI 303
3	Ball DN32-200	AISI 304
4	Stem	
5	Seat	PTFE
6	Handle	Steel
12	Washer	PTFE
13	Body gasket	PTFE
15	Body Screw	Steel DIN 933 5.6
16	Handle screw	Steel DIN 933 5.6
17	Handle Washer	Steel
19	Antistatic device	Stainless steel
72	O ring	FKM
471	Cicrlip	Steel DIN 471
912	Stop screw	Steel DIN 912 8.8
934	Nut	Steel DIN 934.8

CAST IRON BALL VALVE PN 16 LENGTH DIN 3202

VALVE SIZE (in mm) :

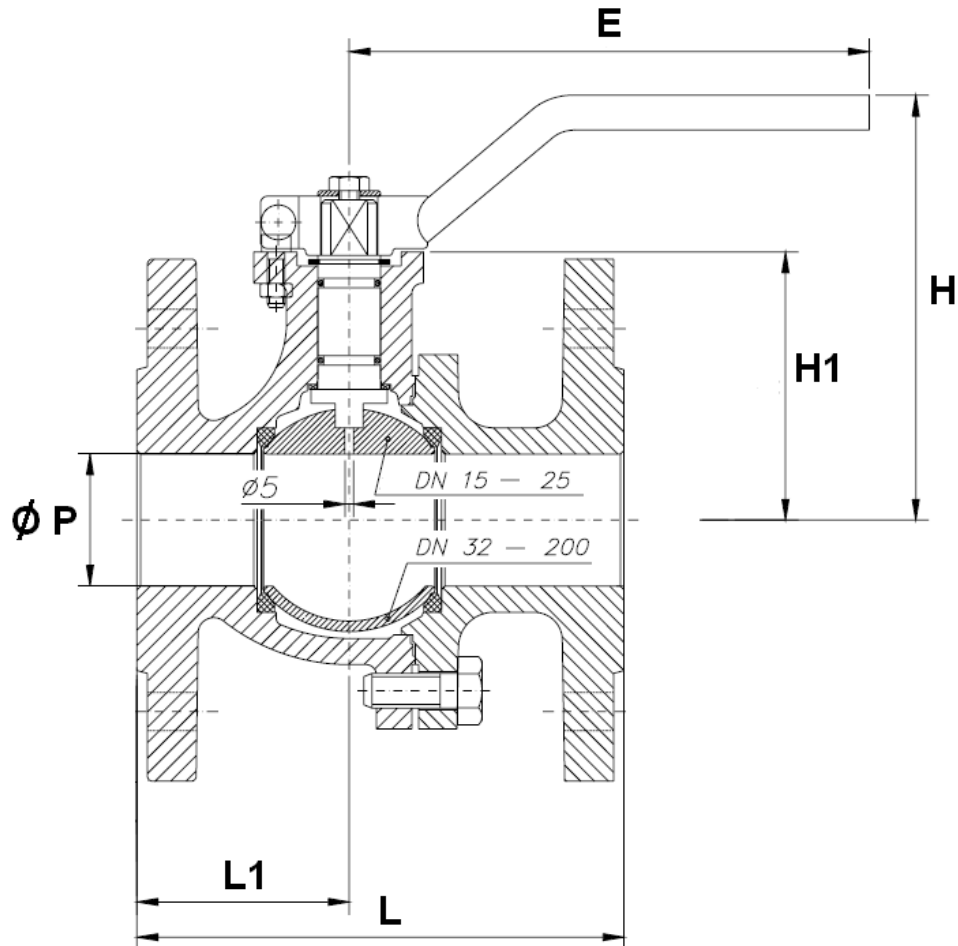

DN	15	20	25	32	40	50	65	80	100	125	125	150	150	200
Ø P	13	17	24	31	38	50	65	80	100	125	125	150	150	200
L	115	120	125	130	140	150	170	180	190	200	325	210	350	400
L1	49	55.5	51.5	53	61	62	81.5	79	94	93	120.5	100	155	190
H	92	95.5	102.2	114.7	119	127	141	151.5	176.5	208	208	254.5	254.5	293.5
H1	48.5	53	59.5	72	77	85	98	108.5	134	165	165	190	190	229
E	170	170	170	170	302.5	302.5	335	335	350	350	350	500	500	500
Weight (Kg)	2.12	2.72	3.62	5.32	6.9	9	11.68	14.68	20.23	33	33.73	47.5	49.77	81.77
Ref.	507015	507020	507025	507032	507040	507050	507065	507080	507100	507125	507126	507150	507151	507200

CAST IRON BALL VALVE PN 16 LENGTH DIN 3202

FLANGES SIZE (in mm) :

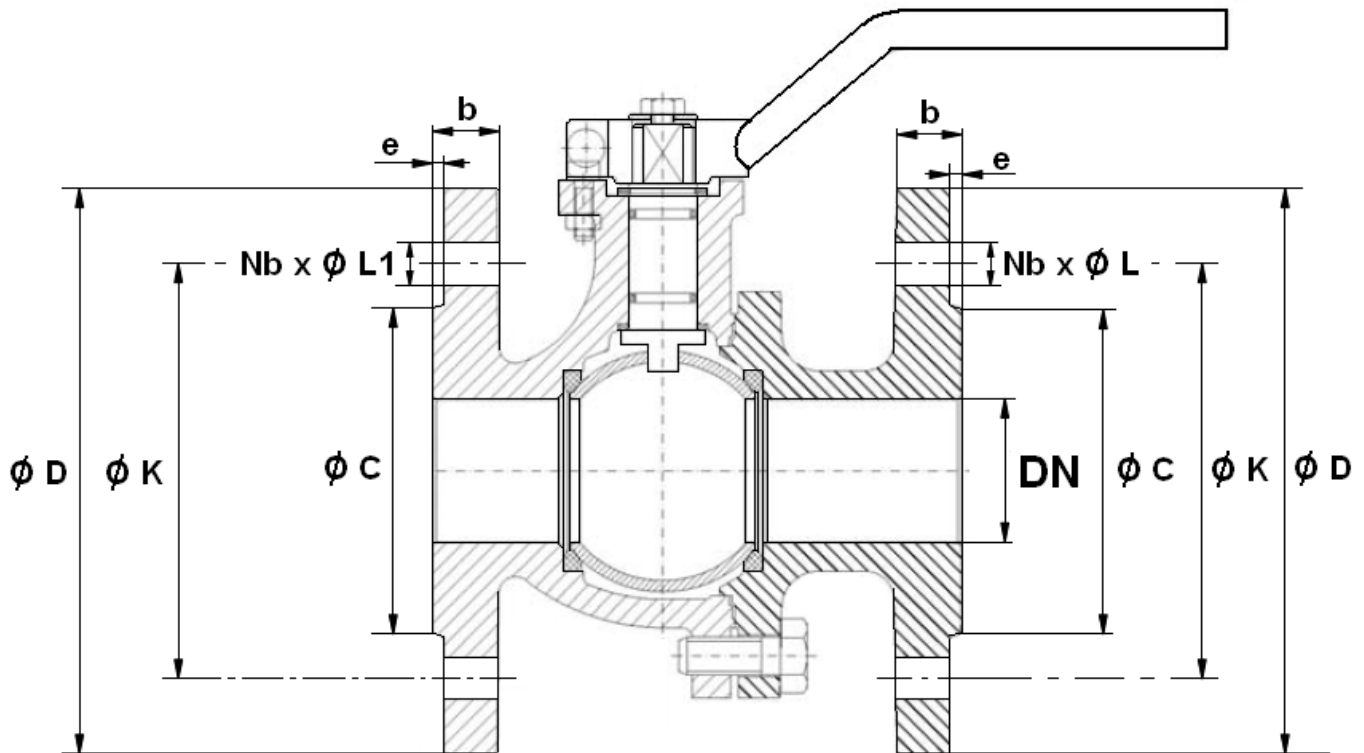

DN	15	20	25	32	40	50	65	80	100	125	150	200
Ø C	45	58	68	78	88	102	122	138	158	188	212	268
Ø D	95	105	115	140	150	165	185	200	220	250	285	340
Ø K	65	75	85	100	110	125	145	160	180	210	240	295
Nb x Ø L	4 x 14	4 x 14	4 x 14	4 x 18	4 x 18	4 x 18	4 x 18	8 x 18	8 x 18	8 x M16	8 x M20	12 x 22
Nb x Ø L1	4 x 14	4 x 14	4 x 14	4 x 18	4 x 18	4 x 18	4 x 18	8 x 18	8 x 18	8 x M16	8 x M20	12 x 22
b	14	16	16	16	16	18	18	20	20	22	22	24
e	2	2	2	2	3	3	3	3	3	3	3	3

CAST IRON BALL VALVE PN 16 LENGTH DIN 3202

STEM AND ISO MOUNTING PAD SIZE (in mm) :

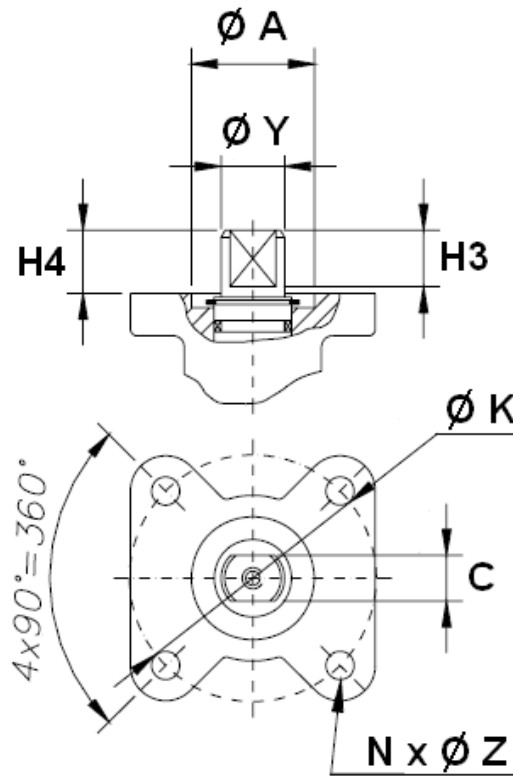

DN	15	20	25	32	40	50	65	80	100	125	150	200
Ø K	42	42	42	42	42	42	70	70	70	70	102	102
ISO	F04	F04	F04	F04	F04	F04	F07	F07	F07	F07	F10	F10
N x Ø Z	4 x 5	4 x 5	4 x 5	4 x 5	4 x 5	4 x 5	4 x 8	4 x 8	4 x 8	4 x 8	4 x 10	4 x 10
C	7	7	7	7	12	12	13	13	16	16	20	20
Ø Y	10	10	10	10	16	16	18	18	22	22	28	28
H3	5.5	5	5	5.5	16	16	19	19	20	20	27	27
H4	7.5	6	6.2	6.7	15	15	18	18	19	19.5	24.5	24.5
Ø A	19	19	21	21	30	30	35	35	38	38	50	50

CAST IRON BALL VALVE PN 16 LENGTH DIN 3202**STANDARDS :**

- Manufacturer certified ISO 9001 :2015
- DIRECTIVE 2014/68/EU : Risk Category I module A from DN65 to DN150
- Valve design according to DIN 3357
- Body design according to DIN 3840
- ISO 5211 mounting pad
- Length according to EN 558 series 27 (DIN 3202 F18) excepted for Ref.507125 and 507150
- Length according to EN 558 series 14 (DIN 3202 F4) from DN 125 to 150 for Refs 507125 and 507150
- Flanges R.F according to EN 1092-2 PN10/16
- Marking according to EN 19
- Pressure tests according to EN 12266-1, Rate A
- ATEX Group II Category 2 G/2Dc Zone 1 & 21 Zone 2 & 22 (optional marking) according to directive 2014/34/EU

ADVICE : Our opinion and our advice are not guaranteed and SFERACO shall not be liable for the consequences of damages.
The customer must check the right choice of the products with the real service conditions.

CAST IRON BALL VALVE PN 16 LENGTH DIN 3202

INSTALLATION INSTRUCTIONS

GENERAL GUIDELINES :

- Ensure that the valves to be used are appropriate for the conditions of the installation (type of fluid, pressure and temperature).
- Be sure to have enough valves to be able to isolate the sections of piping as well as the appropriate equipment for maintenance and repair.
- Ensure that the valves to be installed are of correct strength to be able to support the capacity of their usage.
- **Installation of all circuits should ensure that their function can be automatically tested on a regular basis (at least two times a year).**

INSTALLATION INSTRUCTIONS :

- **Before installing the valves, clean and remove any objects from the pipes** (in particular bits of sealing and metal) which could obstruct and block the valves.
- **Ensure that both connecting pipes either side of the valve (upstream and downstream) are aligned (if they're not, the valves may not work correctly).**
- **Make sure that the two sections of the pipe (upstream and downstream) match, the valve unit will not absorb any gaps. Any distortions in the pipes may affect the tightness of the connection, the working of the valve and can even cause a rupture.** To be sure, place the kit in position to ensure the assembling will work.
- **If sections of piping do not have their final support in place, they should be temporarily fixed. This is to avoid unnecessary strain on the valve.**
- Tighten the bolts in cross.
- It's recommended to operate the valve (open and close) 1 to 2 times per year
- **For an installation in ATEX area, check the conductivity between the valve, the upstream pipe and the downstream pipe and make sure the pipe is connected to the earth.**

